



HAL
open science

A non elliptic spectral problem related to the analysis of superconductive micro-strip lines

Anne-Sophie Bonnet-Ben Dhia, Karim Ramdani

► **To cite this version:**

Anne-Sophie Bonnet-Ben Dhia, Karim Ramdani. A non elliptic spectral problem related to the analysis of superconductive micro-strip lines. *ESAIM: Mathematical Modelling and Numerical Analysis*, 2002, 36 (3), pp.461-487. 10.1051/m2an:2002021 . hal-00990209

HAL Id: hal-00990209

<https://ensta-paris.hal.science/hal-00990209>

Submitted on 14 Feb 2017

HAL is a multi-disciplinary open access archive for the deposit and dissemination of scientific research documents, whether they are published or not. The documents may come from teaching and research institutions in France or abroad, or from public or private research centers.

L'archive ouverte pluridisciplinaire **HAL**, est destinée au dépôt et à la diffusion de documents scientifiques de niveau recherche, publiés ou non, émanant des établissements d'enseignement et de recherche français ou étrangers, des laboratoires publics ou privés.

A NON ELLIPTIC SPECTRAL PROBLEM RELATED TO THE ANALYSIS OF SUPERCONDUCTING MICRO-STRIP LINES

ANNE-SOPHIE BONNET-BENDHIA¹ AND KARIM RAMDANI²

Abstract. This paper is devoted to the spectral analysis of a non elliptic operator A , deriving from the study of superconducting micro-strip lines. Once a sufficient condition for the self-adjointness of operator A has been derived, we determine its continuous spectrum. Then, we show that A is unbounded from below and that it has a sequence of negative eigenvalues tending to $-\infty$. Using the Min-Max principle, a characterization of its positive eigenvalues is given. Thanks to this characterization, some conditions on the geometrical (large width) and physical (large dielectric permittivity in modulus) properties of the strip that ensure the existence of positive eigenvalues are derived. Finally, we analyze the asymptotic behavior of the eigenvalues of A as the dielectric permittivity of the strip goes to $-\infty$.

Mathematics Subject Classification. 35P, 47A70, 47B25, 78A50.

Received: October 11, 2001. Revised: February 25, 2002.

INTRODUCTION

The micro-strip transmission line is one of the most commonly used lines in micro-wave integrated circuits, in order to connect to each other the different micro-electronic components (*cf.* [7, 12]). It is constituted of a thin conducting strip located on a dielectric substrate, which is placed on a conducting ground plane. The line behaves then as an electromagnetic wave-guide, since the energy of the guided modes is confined in the dielectric area located between the conducting strip and the ground plane. Since the discovery of high- T_c superconducting materials fifteen years ago, new lines involving superconducting strips have been realized in order to reduce thermic losses.

As usual in the open wave-guide theory [1, 2, 4, 8], the determination of the guided modes of the superconducting micro-strip line amounts to solve an eigenvalue problem associated to a non compact operator. Because of this non-compactness property, the existence of eigenvalues (*i.e.* the existence of a discrete spectrum), and thus the existence of guided modes, is not ensured. To answer this question, the procedure classically followed in the literature is first to show the self-adjointness of the operator involved in the spectral problem, then to determine its continuous spectrum, and finally to use the Min-Max principle to study the existence of eigenvalues. In the problem studied in this paper, these steps present several specific difficulties, all of them induced by the superconducting properties of the strip. Indeed, in the framework of London's model, superconducting materials

Keywords and phrases. Superconducting transmission lines, wave-guides, self-adjointness, spectral analysis, non elliptic operators.

¹ Laboratoire SMP, ENSTA, URA 853 du CNRS, 32 Boulevard Victor, 75739 Paris Cedex 15, France. e-mail: bonnet@ensta.fr

² Projet CORIDA, INRIA Lorraine, Campus Scientifique, BP 239, 54506 Vandœuvre-les-Nancy, France.

e-mail: ramdani@loria.fr

behave as negative dielectric permittivity materials (*cf.* [9, 11]). The change of sign of the permittivity in the line (negative inside the strip and positive outside) destroys the ellipticity properties of the operator A involved in our spectral problem. The originality of the present work lies in the treatment of this lack of ellipticity and its consequences on the spectral analysis of A (self-adjointness, continuous spectrum, characterization of positive eigenvalues). In [5], an elliptic vector model corresponding to a zero thickness strip (*i.e.* a crack) has been studied. The superconducting properties of the strip were there taken into account through an impedance condition written on its boundary. In this paper, we investigate the difficulties induced by the negative value of the dielectric permittivity of the strip, in the framework of a non elliptic scalar model. Let us emphasize here that this problem cannot be considered as an approximation of the physical vector one. However, it gives rise to similar mathematical difficulties and that's why its study is a necessary preliminary step.

The paper is organized as follows: Section 1 is devoted to the description of the studied scalar model. In Section 2, we give a sufficient condition on the dielectric permittivity of the strip ε_S for self-adjointness. This result is obtained thanks to a perturbation method, using the Dirichlet to Neumann operator. Let us emphasize here that in [3], more precise results about self-adjointness in non elliptic transmission problems have been obtained in the particular case (and simpler compared to the one studied here) where the exterior of the strip is supposed to be homogeneous (see Rem. 2.5). Section 3 is devoted to the determination of the essential spectrum. We prove that this continuous spectrum is the same as the one of the operator corresponding to the perfectly stratified medium obtained after removing the strip. In Section 4, we prove that the operator A involved in our model has a sequence of negative eigenvalues tending to $-\infty$. Thus, it is not bounded from below, and the Min-Max principle cannot be applied to it. In Section 5, a method to overcome this difficulty is proposed. This method is based on the application of the Min-Max principle not to A , but to its inverse A^{-1} . One of the advantages of this method is that it allows one to characterize the positive eigenvalues, which are the only interesting ones from the physical viewpoint. Using the characterization derived, we give then sufficient conditions on the width and the dielectric permittivity of the strip ensuring the existence of a given number of positive eigenvalues. This is achieved using the properties of the one-dimensional problem corresponding to the case of an infinitely wide strip. Finally, in Section 6, it is shown that the more standard case (since it is elliptic) of a perfectly conducting strip can be seen as the asymptotic limit of our problem when the permittivity of the strip goes to $-\infty$. This asymptotic analysis requires the study of a singular perturbation problem, involving a skin effect. The results obtained are then used to derive an asymptotic existence result for positive eigenvalues.

1. MATHEMATICAL SETTING OF THE PROBLEM

Let us start by introducing the notations used throughout the paper.

Given an orthonormal system of coordinates (O, x_1, x_2, x_3) , let the micro-strip line occupy the half-space $x_2 > 0$, and suppose that the direction of propagation is x_3 . We denote by $x = (x_1, x_2)$ the current point of the cross section of the line $\Omega = \{x; x_2 > 0\}$.

The superconducting strip, the dielectric substrate and the air are supposed to occupy respectively the domains having the following sections (see Fig. 1):

- $\Omega_S = \left\{ x = (x_1, x_2), |x_1| < \frac{\ell}{2}, h < x_2 < h + d \right\}$, with boundary $\partial\Omega_S = \Gamma$.
- $\Omega_D = \{x = (x_1, x_2), 0 < x_2 < h\}$, with boundary $\partial\Omega_D = \Gamma_P \cap \Sigma$ where $\Gamma_P = \{x_2 = 0\}$ denotes the cross section of the perfectly conducting ground plane, and $\Sigma = \{x_2 = h\}$ the one of the interface between the dielectric and the air.
- $\Omega_A = \Omega \setminus (\overline{\Omega_D \cup \Omega_S})$.

As it has been already said, superconducting materials behave in the framework of London's model for superconductivity (*cf.* [9, 11]) as materials having negative dielectric permittivity. We shall thus assume in the sequel

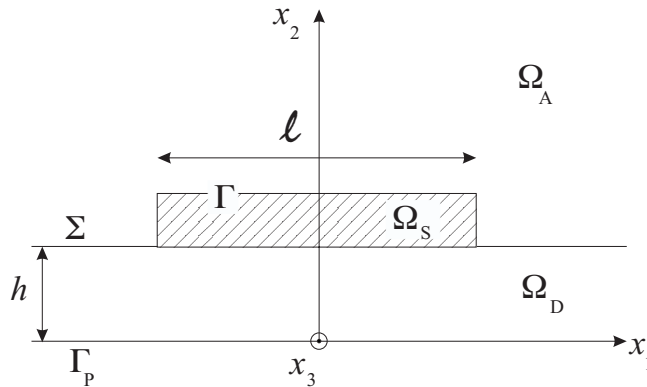

FIGURE 1. The cross section of the micro-strip line.

that the relative dielectric permittivity at any point $x = (x_1, x_2)$ of the cross section Ω is defined as follows:

$$\varepsilon(x) = \begin{cases} \varepsilon_D > 1, & x \in \Omega_D \\ \varepsilon_S < 0, & x \in \Omega_S \\ \varepsilon_A = 1, & x \in \Omega_A. \end{cases}$$

In the model studied in this paper, the guided modes we are looking for are functions of the form:

$$\begin{cases} \mathbf{u}(x, x_3, t) = u(x)e^{i(\omega t - \beta x_3)}, \\ u \in L^2(\Omega) \quad \text{and} \quad \omega, \beta \in \mathbb{R}^* \end{cases} \tag{1}$$

satisfying:

$$\begin{cases} \frac{\partial^2 \mathbf{u}}{\partial t^2} - \operatorname{div} \left(\frac{1}{\varepsilon} \nabla \mathbf{u} \right) = 0 & (\Omega \times \mathbb{R}) \\ \partial_n \mathbf{u} = 0 & (\Gamma_P \times \mathbb{R}) \end{cases} \tag{2}$$

where ∂_n denotes the normal derivative.

Remark 1.1.

(i) The function \mathbf{u} defined by (1) describes a wave propagating in the x_3 -direction without attenuation nor deformation, with the velocity ω/β .

(ii) The operator involved in problem (2) is the one that appears in the description of the transverse magnetic modes of the micro-strip line, in the case of a strip of infinite width.

(iii) The boundary condition on $\Gamma_P \times \mathbb{R}$ is imposed to take into account the fact that the ground plane is perfectly conducting.

(iv) In fact, in the complete London's model for superconductivity, the dielectric permittivity of a superconducting material is not only negative but also frequency-dependent. More precisely, we have:

$$\varepsilon_S = \varepsilon_S(\omega) = -1/(\omega^2 \lambda_L^2),$$

where λ_L is called the London's length and represents the penetration depth of the electromagnetic field inside the superconducting material. For the sake of simplicity, this dependence of ε_S upon frequency has been omitted in the model studied here. Nevertheless, the analysis of the complete model (which is non linear with respect

to the frequency ω) can be carried out by coupling the arguments developed in this paper to a fixed point method (*cf.* [13]).

Substituting (1) into (2) leads immediately to the following eigenvalue problem for the function u describing the transverse behavior of the guided mode \mathbf{u} :

$$\begin{cases} -\operatorname{div}\left(\frac{1}{\varepsilon}\nabla u\right) + \frac{\beta^2}{\varepsilon}u = \omega^2 u & (\Omega) \\ \partial_n u = 0 & (\Gamma_P). \end{cases} \tag{3}$$

In other words, if $\beta \neq 0$ is considered as a parameter, a guided mode can be defined as a solution (ω^2, u) of (3) satisfying $\omega^2 \neq 0$ and $u \neq 0$.

Let us now define a convenient functional framework to study problem (3).

Introduce the unbounded operator A of $L^2(\Omega)$, with domain:

$$D(A) = \left\{ u \in H^1(\Omega), \operatorname{div}\left(\frac{1}{\varepsilon}\nabla u\right) \in L^2(\Omega), \partial_n u|_{\Gamma_P} = 0 \right\},$$

and such that for $u \in D(A)$:

$$Au = -\operatorname{div}\left(\frac{1}{\varepsilon}\nabla u\right) + \frac{\beta^2}{\varepsilon}u.$$

The guided modes we are looking for are then solutions of the spectral problem:

$$\left\{ \begin{array}{l} \text{For } \beta > 0, \text{ find } (\omega, u) \in \mathbb{R}^* \times D(A), u \neq 0, \text{ such that:} \\ Au = \omega^2 u \end{array} \right. \tag{4}$$

Throughout all this paper, $L^2(\Omega)$ will be equipped with the scalar product:

$$(u, v) = \int_{\Omega} u\bar{v},$$

and the associated norm will be noted:

$$\|u\|_{L^2} = \left(\int_{\Omega} |u|^2 \right)^{1/2}.$$

With this hilbertian structure, A is the unbounded operator of $L^2(\Omega)$ associated to the bilinear form $a(\cdot, \cdot)$ defined by:

$$\begin{cases} D(a) = H^1(\Omega) \\ a(u, v) = \int_{\Omega} \frac{1}{\varepsilon} (\nabla u \cdot \nabla \bar{v} + \beta^2 u\bar{v}). \end{cases} \tag{5}$$

To carry out the spectral analysis of A , we shall start by studying its self-adjointness.

2. ABOUT THE SELF-ADJOINTNESS OF A

Operator A is clearly symmetric since it is associated to the symmetric bilinear form $a(\cdot, \cdot)$ defined by (5). We know from classical characterizations of self-adjoint operators that a sufficient condition for self-adjointness of symmetric operators is their surjectivity. Here, because of the change of sign of the permittivity ε , the bilinear

form $a(\cdot, \cdot)$ is not coercive, and the surjectivity of A is far from being obvious. The method we propose to answer this question is based on a perturbation result. More precisely, we shall prove that for “small” or “large” values of the dielectric permittivity ε_S inside the strip, operator A is self-adjoint.

Before stating this result, let us introduce some further notations needed here. We will denote by $\Omega_E = \Omega \setminus \overline{\Omega_S}$ the cross section of the exterior domain, *i.e.* the domain located outside the strip. The outgoing unitary normal vector to Ω_S is noted n . Throughout this section, v_S (respectively v_E) will denote for a given function v defined on Ω its restriction to Ω_S (respectively Ω_E). In particular, the function defining the dielectric permittivity in the cross section of the line satisfies thus:

$$\varepsilon(x) = \begin{cases} \varepsilon_S < 0 & \text{for } x \in \Omega_S \\ \varepsilon_E(x) > 0 & \text{for } x \in \Omega_E \end{cases}$$

where $\varepsilon_E(x) = \varepsilon_A = 1$ in Ω_A and $\varepsilon_E(x) = \varepsilon_D > 1$ in Ω_D .

To study the self-adjointness of A , we are going to study the existence of solutions for the equation:

$$Au = f \tag{6}$$

where f is a given function in $L^2(\Omega)$.

To achieve this, the idea is to transform problem (6) into an equivalent one whose unknown will be the trace $\varphi = u|_\Gamma \in H^{1/2}(\Gamma)$. As a first step, one should notice that problem (6) can be written equivalently as a transmission problem through the interface Γ , with unknowns $u = (u_S, u_E) \in H^1(\Omega_S) \times H^1(\Omega_E)$:

$$(\mathcal{Q}) \begin{cases} (-\Delta + \beta^2) u_S = \varepsilon_S f & (\Omega_S) \\ -\operatorname{div} \left(\frac{1}{\varepsilon_E} \nabla u_E \right) + \frac{\beta^2}{\varepsilon_E} u_E = f & (\Omega_E) \\ u_S - u_E = 0 & (\Gamma) \\ \frac{1}{\varepsilon_S} \partial_n u_S - \frac{1}{\varepsilon_E} \partial_n u_E = 0 & (\Gamma) \\ \partial_n u_E = 0 & (\Gamma_P). \end{cases}$$

Remark 2.1. Since $u_E \in H^1(\Omega_E)$ satisfies $\operatorname{div} \left(\frac{1}{\varepsilon_E} \nabla u_E \right) \in L^2(\Omega_E)$, its normal derivative $\frac{1}{\varepsilon_E} \partial_n u_E|_\Gamma$ can be defined in $H^{-1/2}(\Gamma)$ thanks to the following Green formula that holds for any $v_E \in H^1(\Omega_E)$:

$$\left\langle \frac{1}{\varepsilon_E} \partial_n u_E|_\Gamma, v_E|_\Gamma \right\rangle_\Gamma = - \int_{\Omega_E} \operatorname{div} \left(\frac{1}{\varepsilon_E} \nabla u_E \right) \overline{v_E} \, dx - \int_{\Omega_E} \frac{1}{\varepsilon_E} \nabla u_E \cdot \nabla \overline{v_E} \, dx,$$

the brackets $\langle \cdot, \cdot \rangle_\Gamma$ denoting here the duality between $H^{-1/2}(\Gamma)$ and $H^{1/2}(\Gamma)$.

As a second step, we transform the transmission problem (\mathcal{Q}) into an equivalent one, noted (\mathcal{P}) , in which the only (non-zero) data appears in the normal derivative transmission condition. To achieve this, we use the well-posedness of the following elliptic (since $\beta \neq 0$) Dirichlet problems respectively in $H^1(\Omega_S)$ and $H^1(\Omega_E)$:

$$\begin{cases} (-\Delta + \beta^2) w_S = \varepsilon_S f & (\Omega_S) \\ w_S = 0 & (\Gamma) \end{cases} \quad \begin{cases} -\operatorname{div} \left(\frac{1}{\varepsilon_E} \nabla w_E \right) + \frac{\beta^2}{\varepsilon_E} w_E = f & (\Omega_E) \\ w_E = 0 & (\Gamma) \\ \partial_n w_E = 0 & (\Gamma_P). \end{cases}$$

Consequently, the couple (u_S, u_E) solves (\mathcal{Q}) if and only if $(v_S, v_E) = (u_S - w_S, u_E - w_E)$ satisfies:

$$(\mathcal{P}) \begin{cases} (-\Delta + \beta^2) v_S = 0 & (\Omega_S) \\ -\operatorname{div} \left(\frac{1}{\varepsilon_E} \nabla v_E \right) + \frac{\beta^2}{\varepsilon_E} v_E = 0 & (\Omega_E) \\ v_S - v_E = 0 & (\Gamma) \\ \frac{1}{\varepsilon_S} \partial_n v_S - \frac{1}{\varepsilon_E} \partial_n v_E = g & (\Gamma) \\ \partial_n v_E = 0 & (\Gamma_P) \end{cases}$$

where we have set:

$$g = - \left(\frac{1}{\varepsilon_S} \partial_n w_S - \frac{1}{\varepsilon_E} \partial_n w_E \right)_{|\Gamma} \in H^{-1/2}(\Gamma).$$

Now, to study the well-posedness of (\mathcal{P}) , we introduce the Dirichlet to Neumann operators T_S and T_E , defined for any trace φ in $H^{1/2}(\Gamma)$ by the relations:

$$\begin{cases} T_S \varphi = \partial_n v_S(\varphi)_{|\Gamma} \\ T_E \varphi = \frac{1}{\varepsilon_S} \partial_n v_E(\varphi)_{|\Gamma} \end{cases}$$

where $v_S(\varphi)$ and $v_E(\varphi)$ solve respectively the interior and exterior Dirichlet problems with data φ :

$$\begin{cases} (-\Delta + \beta^2) v_S(\varphi) = 0 & (\Omega_S) \\ v_S(\varphi) = \varphi & (\Gamma) \end{cases} \quad \begin{cases} -\operatorname{div} \left(\frac{1}{\varepsilon_E} \nabla v_E(\varphi) \right) + \frac{\beta^2}{\varepsilon_E} v_E(\varphi) = 0 & (\Omega_E) \\ v_E(\varphi) = \varphi & (\Gamma) \\ \partial_n v_E(\varphi) = 0 & (\Gamma_P). \end{cases}$$

Note that these problems being well-posed, operators T_S et T_E define isomorphisms from $H^{1/2}(\Gamma)$ onto $H^{-1/2}(\Gamma)$. Solving (\mathcal{P}) is then equivalent to solve the following equation:

$$\left(\frac{1}{\varepsilon_S} T_S - T_E \right) \varphi = g. \tag{7}$$

We are now able to derive a sufficient condition on ε_S ensuring the well-posedness of (\mathcal{P}) :

Lemma 2.2. *There exists $c > 0$ such that for every $\varepsilon_S \in]-\infty, -c[\cup]-1/c, 0[$, problem (\mathcal{P}) , and thus problem (\mathcal{Q}) , admits a unique solution.*

Proof. Since T_E is an isomorphism, the invertibility of $\left(\frac{1}{\varepsilon_S} T_S - T_E \right)$ is equivalent to the invertibility of $\left(\frac{1}{\varepsilon_S} T_E^{-1} T_S - \operatorname{Id} \right)$, which is clearly satisfied if:

$$\left| \frac{1}{\varepsilon_S} \right| \|T_E^{-1} T_S\| < 1.$$

Consequently, if $|\varepsilon_S| > \|T_E^{-1} T_S\|$, problems (\mathcal{P}) and (\mathcal{Q}) are well-posed. Applying the same kind of arguments to the operator $\operatorname{Id} - \varepsilon_S T_S^{-1} T_E$, we can prove the well-posedness of (\mathcal{P}) and (\mathcal{Q}) for $|\varepsilon_S| < \|T_S^{-1} T_E\|^{-1}$. The lemma is thus proved, with: $c = \max(\|T_E^{-1} T_S\|, \|T_S^{-1} T_E\|)$. □

Remark 2.3. Notice that the constant $c = \max(\|T_E^{-1}T_S\|, \|T_S^{-1}T_E\|)$ satisfies $c \geq 1$, since:

$$\|T_E^{-1}T_S\| \|T_S^{-1}T_E\| \geq \|T_E^{-1}T_S T_S^{-1}T_E\| = 1.$$

We immediately deduce from this lemma the main result of this section:

Theorem 2.4. *There exists a constant $c > 0$ such that for:*

$$\varepsilon_S \in]-\infty, -c[\cup] -1/c, 0[, \tag{8}$$

the symmetric operator A is invertible and thus self-adjoint.

From now on, we will assume that the dielectric permittivity of the strip ε_S satisfies condition (8), and thus that A is self-adjoint.

Remark 2.5.

(i) In fact, the result of Theorem 2.4 can be precised in the special case where the exterior of the strip is supposed to be homogeneous (*i.e.*: $\varepsilon_D = \varepsilon_A$). This particular case, and more generally the question of self-adjointness of non elliptic transmission operators through a regular or polygonal interface between two media has been investigated in [3]. For regular interfaces, it is proved in [3] that the problem is self-adjoint if and only if $\varepsilon_S/\varepsilon_A \neq -1$. For polygonal interfaces, it is proved that for some negative values of the contrast $\varepsilon_S/\varepsilon_A$ constituting an interval containing -1 , the operator A is not self-adjoint. More precisely, if the interface has only one corner of angle $0 < \theta \leq \pi$, the operator is self-adjoint if and only if

$$\frac{\varepsilon_S}{\varepsilon_A} \notin I_\theta = \left[\frac{\theta - 2\pi}{\theta}, \frac{\theta}{\theta - 2\pi} \right].$$

This result is directly related to the fact that for these values of the contrast, the domain of the adjoint A^* of A contains some corner singularities which are too strong (L^2 but not H^1) to belong to the domain $D(A)$ of A .

(ii) In our problem, we can distinguish two kinds of corners: the upper corners of the strip corresponding to a two-media interface, and the lower ones, corresponding to a three-media interface. For the upper ones, the results of [3] can be applied, while for the lower ones, one needs to generalize the method proposed in [3] to the case of a three-media interface. Nevertheless, note that [3] already shows that our operator A is not self-adjoint (at least) for $\varepsilon_S \in I_{\pi/2} = [-3, -1/3]$, because of the singularities generated by the upper corners. Consequently, the constant c in Theorem 2.4 satisfies $c > 3$.

(iii) In the framework of London’s model, the superconducting material becomes better as ε_S decreases, and thus, as the penetration depth of the electromagnetic field inside the strip gets smaller. In particular, the limit case $\varepsilon_S = -\infty$ corresponds to a zero penetration depth, and can thus be interpreted as the case of a perfectly conducting strip (*cf.* Sect. 6).

3. THE ESSENTIAL SPECTRUM

Since operator A is self-adjoint, its spectrum is real. Moreover, because Ω is unbounded, the embedding of $D(A)$ in $L^2(\Omega)$ is not compact, and thus the spectrum of A has a continuous part, the so-called essential spectrum. Our aim here is to determine this continuous part. Using the fact that the strip has a bounded section, we are going to prove that the essential spectrum of A is identical to the one of the operator A_∞ associated to the unperturbed medium. Here, we mean by unperturbed medium the medium constituted by the air and the dielectric substrate, obtained after the strip has been removed. In other words, the result established here is a stability result for the essential spectrum, under a compact geometric perturbation. The main difficulty of the proof is once again due to the loss of coercivity induced by the change of sign of ε .

Before stating more precisely the main result of this section, let us introduce some notations in order to define the operator A_∞ corresponding to the unperturbed medium. Set:

$$\varepsilon_\infty(x) = \varepsilon_\infty(x_2) = \begin{cases} \varepsilon_D > 1 & \text{in } \Omega_D \\ \varepsilon_A = 1 & \text{in } \Omega \setminus \overline{\Omega}_D. \end{cases}$$

Note that ε_∞ is nothing but the function describing the (relative) dielectric permittivity of the unperturbed medium. Then, define operator A_∞ as follows:

$$\begin{cases} D(A_\infty) = \left\{ u \in H^1(\Omega), \operatorname{div} \left(\frac{1}{\varepsilon_\infty} \nabla u \right) \in L^2(\Omega), \partial_n u|_{\Gamma_P} = 0 \right\} \\ A_\infty u = -\operatorname{div} \left(\frac{1}{\varepsilon_\infty} \nabla u \right) + \frac{\beta^2}{\varepsilon_\infty} u. \end{cases} \tag{9}$$

The essential spectrum of A is then given by

Theorem 3.1.

$$\sigma_{\text{ess}}(A) = \sigma(A_\infty) = [\gamma_{\text{TM}}, +\infty[$$

where γ_{TM} is defined by the formula:

$$\gamma_{\text{TM}} = \inf_{u \in H^1(\mathbb{R}^+), u \neq 0} \frac{\int_0^{+\infty} \frac{1}{\varepsilon_\infty(x_2)} \left(\left| \frac{du}{dx_2} \right|^2 + \beta^2 |u|^2 \right) dx_2}{\int_0^{+\infty} |u|^2 dx_2}. \tag{10}$$

Remark 3.2. The equation $\omega^2 = \gamma_{\text{TM}}$ (relating the frequency ω and the wave-number β) is the dispersion relation of the fundamental transverse magnetic guided mode of the slab waveguide (cf. [10]). From a mathematical point of view, γ_{TM} represents the first eigenvalue of the self-adjoint operator A_{TM} defined on $L^2(\mathbb{R}^+)$ by:

$$\begin{cases} D(A_{\text{TM}}) = \left\{ u \in H^1(\mathbb{R}^+); \frac{d}{dx_2} \left(\frac{1}{\varepsilon_\infty} \frac{du}{dx_2} \right) \in L^2(\mathbb{R}^+), \frac{du}{dx_2}(0) = 0 \right\} \\ A_{\text{TM}} u = -\frac{d}{dx_2} \left(\frac{1}{\varepsilon_\infty} \frac{du}{dx_2} \right) + \frac{\beta^2}{\varepsilon_\infty} u. \end{cases}$$

One can easily check (cf. [10]) that γ_{TM} is the first positive solution of the the dispersion relation:

$$\tan(\kappa h) = \varepsilon_D \eta / \kappa, \tag{11}$$

where we have set $\kappa = \sqrt{\gamma_{\text{TM}} \varepsilon_D - \beta^2}$ and $\eta = \sqrt{\beta^2 - \gamma_{\text{TM}}}$. Using this property, one can in particular prove that γ_{TM} satisfies:

$$\frac{\beta^2}{\varepsilon_D} < \gamma_{\text{TM}} < \beta^2.$$

To prove Theorem 3.1, we shall successively prove (in Lems. 3.3, 3.4 and 3.5) the following inclusions:

$$\sigma(A_\infty) \subset [\gamma_{\text{TM}}, +\infty[\quad , \quad [\gamma_{\text{TM}}, +\infty[\subset \sigma_{\text{ess}}(A) \quad , \quad \sigma_{\text{ess}}(A) \subset \sigma_{\text{ess}}(A_\infty). \tag{12}$$

In fact, the difficulties due to the non ellipticity of A appear only in the proof of the last inclusion, making it slightly more complicated than the two first ones.

Lemma 3.3.

$$\sigma(A_\infty) \subset [\gamma_{TM}, +\infty[.$$

Proof. From the definition of γ_{TM} , we have for almost every $x_1 \in \mathbb{R}$ and every $u \in D(A_\infty)$:

$$\int_{\mathbb{R}^+} \frac{1}{\varepsilon_\infty} \left(\left| \frac{du}{dx_2} \right|^2 + \beta^2 |u|^2 \right) dx_2 \geq \gamma_{TM} \int_{\mathbb{R}^+} |u|^2 dx_2.$$

Integrating this inequality with respect to x_1 , one obtains that:

$$(A_\infty u, u) = \int_\Omega \frac{1}{\varepsilon_\infty} \left(\left| \frac{du}{dx_2} \right|^2 + \beta^2 |u|^2 \right) dx_1 dx_2 \geq \gamma_{TM} \|u\|^2, \quad \forall u \in D(A_\infty).$$

Since A_∞ is self-adjoint, we have thus:

$$\inf \sigma(A_\infty) = \inf_{u \in D(A_\infty), u \neq 0} \frac{(A_\infty u, u)}{\|u\|^2} \geq \gamma_{TM},$$

and the lemma is proved. □

Let us now prove the second inclusion of (12).

Lemma 3.4.

$$[\gamma_{TM}, +\infty[\subset \sigma_{\text{ess}}(A).$$

Proof. We are going to show that we can associate to every $\lambda \geq \gamma_{TM}$ a singular sequence of A . To achieve this, we introduce the function:

$$k \longrightarrow \Gamma_{TM}(k) = \inf_{u \in H^1(\mathbb{R}^+), u \neq 0} \frac{\int_0^{+\infty} \frac{1}{\varepsilon_\infty(x_2)} \left(\left| \frac{du}{dx_2} \right|^2 + k^2 |u|^2 \right) dx_2}{\int_0^{+\infty} |u|^2 dx_2},$$

such that: $\Gamma_{TM}(\beta) = \gamma_{TM}$. Then, we notice that the function:

$$\xi \longrightarrow \Gamma_{TM}(\sqrt{\beta^2 + \xi^2})$$

is continuous and strictly increasing on \mathbb{R}^+ , and is thus bijective from \mathbb{R}^+ onto $[\Gamma_{TM}(\beta), +\infty[= [\gamma_{TM}, +\infty[$. Consequently, for every $\lambda \geq \gamma_{TM}$, there exists a unique $\xi \geq 0$ such that:

$$\lambda = \Gamma_{TM}(k), \quad k = \sqrt{\beta^2 + \xi^2}.$$

To build up a singular sequence associated to λ , we use the planar wave-guide fundamental mode u_k associated to $\Gamma_{TM}(k)$. More precisely, u_k satisfies:

$$\begin{cases} \int_0^{+\infty} |u_k(x_2)|^2 dx_2 = 1, \\ -\frac{d}{dx_2} \left(\frac{1}{\varepsilon_\infty} \frac{du_k}{dx_2} \right) + \frac{k^2}{\varepsilon_\infty} u_k = \Gamma_{TM}(k) u_k, \\ \frac{du_k}{dx_2}(0) = 0. \end{cases} \tag{13}$$

Let $\theta \in C^\infty(\mathbb{R})$ such that $\theta_{|[-\ell/2, \ell/2]} = 0$ (recall that ℓ is the width of the strip) and $\int_{-\infty}^{+\infty} |\theta(x_1)|^2 dx_1 = 1$. Consider the sequence u_n of $H^1(\Omega)$ defined by:

$$u_n(x) = \theta_n(x_1) e^{i\xi x_1} u_k(x_2),$$

where:

$$\theta_n(x_1) = \frac{1}{\sqrt{n}} \theta\left(\frac{x_1}{n}\right).$$

One can easily check that:

$$\begin{cases} \|u_n\|_{L^2} = 1, \\ u_n \rightharpoonup 0 \text{ dans } L^2(\Omega), \\ u_n \in D(A). \end{cases}$$

In addition, the second equation of (13) shows that we have in Ω_D and Ω_A :

$$\begin{aligned} Au_n &= \theta_n e^{i\xi x_1} \frac{1}{\varepsilon_\infty} \left(-\frac{d^2 u_k}{dx_2^2} + k^2 u_k \right) - \frac{2}{\varepsilon_\infty} i\xi \frac{d\theta_n}{dx_1} e^{i\xi x_1} u_k - \frac{1}{\varepsilon_\infty} \frac{d^2 \theta_n}{dx_1^2} e^{i\xi x_1} u_k \\ &= \lambda u_n - \frac{2}{\varepsilon_\infty} i\xi \frac{d\theta_n}{dx_1} e^{i\xi x_1} u_k - \frac{1}{\varepsilon_\infty} \frac{d^2 \theta_n}{dx_1^2} e^{i\xi x_1} u_k. \end{aligned}$$

Since $\frac{d\theta_n}{dx_1}$ and $\frac{d^2 \theta_n}{dx_1^2}$ converge strongly to zero in $L^2(\mathbb{R})$, we have thus: $\|Au_n - \lambda u_n\|_{L^2} \rightarrow 0$. Consequently, $\lambda = \Gamma_{\text{TM}}\left(\sqrt{\beta^2 + \xi^2}\right)$ belongs to $\sigma_{\text{ess}}(A)$ for every $\xi \geq 0$, and thus $[\Gamma_{\text{TM}}(\beta), +\infty[= [\gamma_{\text{TM}}, +\infty[\subset \sigma_{\text{ess}}(A)$. \square

To conclude the proof of Theorem 3.1, let us prove the last and most difficult inclusion:

Lemma 3.5.

$$\sigma_{\text{ess}}(A) \subset \sigma_{\text{ess}}(A_\infty).$$

Proof. Let $\lambda \in \sigma_{\text{ess}}(A)$ and $u_n \in D(A)$ be a singular sequence associated to λ :

$$\begin{cases} \|u_n\|_{L^2} = 1, \\ u_n \rightharpoonup 0 \text{ in } L^2(\Omega), \\ \|Au_n - \lambda u_n\|_{L^2} \rightarrow 0. \end{cases}$$

In order to build up a singular sequence of A_∞ associated to λ , set: $v_n = \theta u_n$ where $\theta \in C_0^\infty(\Omega)$ satisfies:

- $\forall x \in \Omega_\infty: 0 \leq \theta(x) \leq 1$.
- There exist two open sets \mathcal{O} and \mathcal{O}' of Ω such that:

$$\begin{cases} \Omega_S \subset \mathcal{O} \subset \mathcal{O}', \\ \theta = 0 \quad \text{in } \mathcal{O}, \\ \theta = 1 \quad \text{in } \Omega \setminus \mathcal{O}'. \end{cases}$$

- $\theta(x_1, x_2) = \theta(x_1)$ in the vicinity of the interface $\Sigma = \{x_2 = h\}$ between the dielectric and the air.

We shall prove that v_n is a singular sequence of A_∞ associated to λ .

First, it is clear that v_n belongs to the domain $D(A_\infty)$ of A_∞ , and that it converges weakly to zero in $L^2(\Omega)$. To conclude, it remains to prove that:

- (i) v_n does not converge (strongly) to zero in $L^2(\Omega)$.
- (ii) $A_\infty v_n - \lambda v_n$ converges to zero in $L^2(\Omega)$.

These results will follow from the properties of operator A stated below.

Theorem 2.4 shows that operator A defines an isomorphism from $D(A)$ onto $L^2(\Omega)$. As a consequence, there exists $C > 0$ such that:

$$\|u\|_{H^1(\Omega)} \leq C \|Au\|_{L^2}, \quad \forall u \in D(A). \tag{14}$$

Furthermore, classical regularity results for elliptic transmission problems show that u has an H^2 -regularity on both sides of the interface $\Sigma \setminus (\Sigma \cap \Gamma)$ between the air and the dielectric substrate. Consequently, if \mathcal{U} is an open set such that $\mathcal{U} \cap \Gamma = \emptyset$, the following estimate holds:

$$\|u\|_{H^2(\mathcal{U} \cap \Omega_D)} + \|u\|_{H^2(\mathcal{U} \cap \Omega_A)} \leq C \|Au\|_{L^2}, \quad \forall u \in D(A).$$

- (i) Applying these results to the sequence u_n , one obtains that:

$$\|u_n\|_{H^1(\Omega)} \leq C \|Au_n\|_{L^2}. \tag{15}$$

On the other hand, since: $(Au_n, u_n) = (Au_n - \lambda u_n, u_n) + \lambda \|u_n\|_{L^2}^2$, the sequence Au_n is bounded in $L^2(\Omega)$. Inequality (15) shows that u_n converges (up to a subsequence) to zero in $L^2_{loc}(\Omega)$. Consequently, the function $1 - \theta$ having a compact support, we have:

$$\|v_n\|_{L^2} = \|\theta u_n\|_{L^2} = \|u_n - (1 - \theta)u_n\|_{L^2} \longrightarrow 1,$$

and point (i) is thus proved.

- (ii) A straightforward computation shows that:

$$A_\infty v_n - \lambda v_n = \theta (Au_n - \lambda u_n) - \frac{1}{\varepsilon_\infty} (u_n \Delta \theta + 2\nabla \theta \cdot \nabla u_n).$$

Since $\Delta \theta$ has a compact support and since the sequence u_n converges to zero in $L^2_{loc}(\Omega)$, we have:

$$\lim_{n \rightarrow +\infty} \|u_n \Delta \theta\|_{L^2} = 0.$$

If \mathcal{U} denotes the support of $\nabla \theta$, the regularity results recalled above show that:

$$\|u_n\|_{H^2(\mathcal{U} \cap \Omega_D)} + \|u_n\|_{H^2(\mathcal{U} \cap \Omega_A)} \leq C \|Au_n\|_{L^2}.$$

Thus, the sequence u_n converges to zero in $H^1(\mathcal{U})$ and consequently:

$$\lim_{n \rightarrow +\infty} \|\nabla \theta \cdot \nabla u_n\|_{L^2} = 0.$$

As a consequence:

$$\lim_{n \rightarrow +\infty} \|A_\infty v_n - \lambda v_n\|_{L^2} = 0,$$

and v_n is a singular sequence of A_∞ associated to λ . □

4. NEGATIVE EIGENVALUES

In this section, we are going to see that A has a sequence of negative eigenvalues that converges to $-\infty$. This property is directly related to the negative value of the dielectric permittivity in the superconducting strip.

Let us start by proving the following preliminary result:

Proposition 4.1. *Operator A is not bounded from below.*

Proof. To prove this proposition, we construct a sequence $u_n \in D(A)$ satisfying:

$$\begin{cases} \|u_n\|_{L^2} = 1, \forall n \geq 0 \\ \lim_{n \rightarrow +\infty} (Au_n, u_n) = -\infty. \end{cases} \tag{16}$$

Let $x_0 \in \Omega_S$ and $\delta > 0$ be such that the ball $\mathcal{B} = \{x, |x - x_0| < \delta\}$ is contained in Ω_S . We define then the sequence:

$$u_n(x) = n \theta(n|x - x_0|),$$

where θ is a regular radial function with support in \mathcal{B} , such that $\|\theta\|_{L^2} = 1$.

Since $\text{Supp } u_n \subset \{|x - x_0| < \delta/n\} \subset \Omega_S$, we have $u_n \in D(A)$. Furthermore:

$$\|u_n\|_{L^2} = 1 \quad \text{and} \quad \|\nabla u_n\|_{L^2} = n \|\nabla \theta\|_{L^2}.$$

As a consequence:

$$(Au_n, u_n) = \frac{1}{\varepsilon_S} \int_{\Omega_S} (|\nabla u_n|^2 + \beta^2 |u_n|^2) = \frac{1}{\varepsilon_S} (n^2 \|\nabla \theta\|_{L^2}^2 + \beta^2) \longrightarrow -\infty. \quad \square$$

We immediately deduce from this proposition the:

Corollary 4.2. *Operator A admits a sequence of negative eigenvalues tending to $-\infty$.*

Proof. Since A is self-adjoint, we have:

$$\inf \sigma(A) = \inf_{u \in D(A), u \neq 0} \frac{(Au, u)}{\|u\|_{L^2}^2},$$

where $\sigma(A)$ denotes the spectrum of A . Thus, it follows from Proposition 4.1 that: $\inf \sigma(A) = -\infty$. On the other hand, if $\sigma_p(A)$ denotes the point spectrum of A , which is composed of isolated eigenvalues of finite multiplicity, we have:

$$\sigma(A) = \sigma_{\text{ess}}(A) \cup \sigma_p(A) = [\gamma_{\text{TM}}, +\infty[\cup \sigma_p(A).$$

Consequently: $\inf \sigma_p(A) = -\infty$. This shows the existence of a sequence λ_n of negative eigenvalues of A satisfying: $\lim_{n \rightarrow +\infty} \lambda_n = -\infty$. □

We shall now make use of these results concerning the spectrum of A to prove the existence of positive eigenvalues of A .

5. POSITIVE EIGENVALUES

Applying the Min-Max principle to operator A^{-1} , we derive in the first part of this section a necessary and sufficient condition for the existence of positive eigenvalues. In the second part, we use the condition previously derived to prove existence results for positive eigenvalues of A .

5.1. Characterization of the positive eigenvalues of A

The Min-Max principle (*cf.* [14]) provides a criterion to prove existence of eigenvalues located below the essential spectrum for self-adjoint bounded from below operators. More precisely, let B be such an operator with domain $D(B) \subset L^2(\Omega)$, $b(\cdot, \cdot)$ the bilinear form with domain $D(b)$ associated to it, and $\gamma_{\text{ess}} = \inf \sigma_{\text{ess}}(B)$.

For $m \geq 1$, we introduce the real numbers λ_m equivalently defined by the two formulas:

$$\lambda_m = \inf_{V_m \in \mathcal{V}_m(D(B))} \sup_{u \in V_m, u \neq 0} \frac{(Bu, u)}{\|u\|_{L^2}^2} = \inf_{V_m \in \mathcal{V}_m(D(b))} \sup_{u \in V_m, u \neq 0} \frac{b(u, u)}{\|u\|_{L^2}^2} \tag{17}$$

where $\mathcal{V}_m(V)$ denotes the set of all m -dimensional subspaces of V .

The Min-Max principle states that operator B has at least m eigenvalues λ satisfying $\lambda < \gamma_{\text{ess}}$ if and only if $\lambda_m < \gamma_{\text{ess}}$. In other words, if \mathcal{N} denotes the number of such eigenvalues, the following assertion holds:

$$\lambda_m < \gamma_{\text{ess}} \iff \mathcal{N} \geq m \tag{18}$$

Furthermore, if $\mathcal{N} \geq m$, the m first eigenvalues of B are exactly the numbers λ_p , $1 \leq p \leq m$.

In the case studied here, operator A is neither bounded from below (because of its infinite sequence of negative eigenvalues, *cf.* Prop. 4.1), and of course, nor from above. Consequently, the Min-Max principle cannot be applied to it. We have thus to find a new criterion for existence of eigenvalues. Moreover, we have an extra constraint concerning the construction of this criterion: it must be sharp enough to prove the existence of **positive** eigenvalues for A , since these eigenvalues are the only ones of interest from the physical point of view. To achieve this, the solution we propose is to apply the Min-Max principle to the operator A^{-1} (recall that condition (8) is supposed to be satisfied and that A is thus invertible).

Since $\lambda \in \sigma(A)$ if and only if $\lambda^{-1} \in \sigma(A^{-1})$, Theorem 3.1 and Corollary 4.2 lead to:

Proposition 5.1. *Operator A^{-1} is self-adjoint, bounded from below and from above. Moreover, A^{-1} has a sequence of negative eigenvalues tending to zero, and its continuous spectrum is $]0, (\gamma_{\text{TM}})^{-1}[$.*

Figures 2 and 3 below show the structure of the spectra of A and A^{-1} . As it can be seen from these figures, we have:

$$\lambda \in \sigma_p(A) \cap \mathbb{R}^+ \iff \mu = 1/\lambda \in \sigma_p(A^{-1}) \quad \text{and} \quad \mu > 1/\gamma_{\text{TM}}.$$

Consequently, the determination of the positive eigenvalues of A amounts to the determination of the eigenvalues of A^{-1} located above its essential spectrum. Applying the Min-Max principle to the self-adjoint and bounded from below operator $B = -A^{-1}$, we obtain the following result:

Theorem 5.2. *Let \mathcal{N} be the number of positive eigenvalues λ of A satisfying $\lambda < \gamma_{\text{TM}}$ (counted with their multiplicity), and define:*

$$\mu_m = \sup_{V_m \in \mathcal{V}_m(D(A))} \inf_{u \in V_m, u \neq 0} \frac{(Au, u)}{\|Au\|_{L^2}^2}. \tag{19}$$

Then, for all $m \geq 1$:

$$\mathcal{N} \geq m \iff \mu_m > \frac{1}{\gamma_{\text{TM}}}. \tag{20}$$

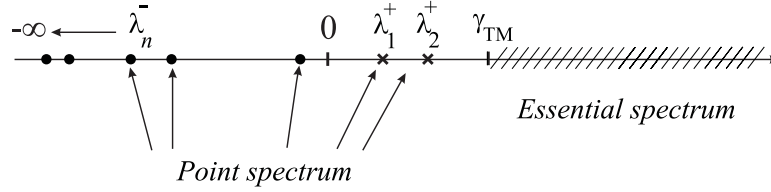

FIGURE 2. Spectrum of A .

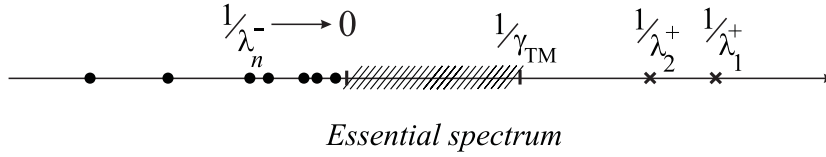

FIGURE 3. Spectrum of A^{-1} .

In addition, if $\mathcal{N} \geq m$, the first m eigenvalues λ_p , $p = 1, \dots, m$, of A are given by the relation:

$$\lambda_p = \frac{1}{\mu_p}.$$

Proof. Denote by $\lambda_m(B)$ the min-max of order m of $B = -A^{-1}$, and by $\mathcal{N}(B)$ the number of its eigenvalues which are smaller than the lower bound $-\frac{1}{\gamma_{TM}}$ of its essential spectrum. Applying the Min-Max principle to the self-adjoint bounded from below operator B , we obtain that:

$$\mathcal{N}(B) \geq m \iff \lambda_m(B) < -\frac{1}{\gamma_{TM}}, \tag{21}$$

and that, if $\mathcal{N}(B) \geq m$, the numbers $\lambda_p(B)$, $p = 1, \dots, m$ are exactly the m first eigenvalues of B .

On the other hand, using the min-max formula, we have:

$$\begin{aligned} \lambda_m(B) &= \inf_{V_m \in \mathcal{V}_m(L^2(\Omega))} \sup_{f \in V_m, f \neq 0} \frac{(-A^{-1}f, f)}{\|f\|_{L^2}^2} \\ &= - \sup_{V_m \in \mathcal{V}_m(L^2(\Omega))} \inf_{f \in V_m, f \neq 0} \frac{(A^{-1}f, f)}{\|f\|_{L^2}^2} \\ &= - \sup_{V_m \in \mathcal{V}_m(D(A))} \inf_{u \in V_m, u \neq 0} \frac{(Au, u)}{\|Au\|_{L^2}^2} \\ &= -\mu_m. \end{aligned}$$

Furthermore, $\mathcal{N}(B)$ is nothing but \mathcal{N} . The equivalence (21) shows thus that:

$$\mathcal{N} \geq m \iff \mu_m > \frac{1}{\gamma_{TM}}.$$

Finally, since the numbers $\lambda_p(B) = -\mu_p$, for $p = 1, \dots, m$ are the m first eigenvalues of $B = -A^{-1}$, the positive real numbers $(\mu_p^{-1})_{p=1, \dots, m}$ are the m first positive ones of A . □

Remark 5.3.

(i) The existence criterion (20) for positive eigenvalues can also be written:

$$\mathcal{N} \geq m \iff \left\{ \begin{array}{l} \exists V_m \in \mathcal{V}_m(D(A)), \text{ such that } \forall u \in V_m \\ \gamma_{\text{TM}}(Au, u) > \|Au\|_{L^2}^2. \end{array} \right. \tag{22}$$

(ii) One may notice that the criterion obtained imposes that the test functions of V_m belong to the domain $D(A)$ of the operator, and satisfy in particular the suitable transmission conditions at the interfaces. This constraint makes the construction of such test functions much more complicated than in the usual case of an operator bounded from below. Indeed, in this last case, the m -dimensional subspaces V_m are not included in the domain of the operator, but in the one of the bilinear form associated to it.

We shall now use the characterization obtained to prove existence results for positive eigenvalues λ of A satisfying $\lambda < \gamma_{\text{TM}}$.

5.2. Existence results for positive eigenvalues

In this section, we are going to show how the criterion derived in Section 5.1 can be used to prove the existence of positive eigenvalues of the operator A . As stated in the point (i) of Remark 5.3, operator A admits at least m positives eigenvalues smaller than γ_{TM} if and only if there exists an m -dimensional subspace V_m of $D(A)$ such that:

$$\gamma_{\text{TM}}(Au, u) > \|Au\|_{L^2}^2, \quad \forall u \in V_m.$$

We will see that the existence of such a subspace can be proved if the strip is wide enough, and its permittivity large enough (in modulus). This result is based on the fact that for large strips, the problem is “close” to the one-dimensional problem corresponding to the case of an infinitely wide strip. On the other hand, and as we shall see in the next section, this problem can be studied almost explicitly (see [6]), and has at least one positive eigenvalue for $|\varepsilon_S|$ large enough.

5.2.1. The one-dimensional model (strip of infinite width)

This model is associated to the unbounded operator A^1 of $L^2(\mathbb{R}^+)$, defined by:

$$\left\{ \begin{array}{l} D(A^1) = \left\{ u \in H^1(\mathbb{R}^+), \frac{d}{dx_2} \left(\frac{1}{\varepsilon} \frac{du}{dx_2} \right) \in L^2(\mathbb{R}^+), \frac{du}{dx_2}(0) = 0 \right\} \\ A^1 u = -\frac{d}{dx_2} \left(\frac{1}{\varepsilon} \frac{du}{dx_2} \right) + \frac{\beta^2}{\varepsilon} u, \end{array} \right. \tag{23}$$

where, for the sake of simplicity, we still denote by ε the function of x_2 defined by:

$$\varepsilon(x_2) = \begin{cases} \varepsilon_D > 1 & 0 < x_2 < h \\ \varepsilon_S < 0 & h < x_2 < h + d \\ \varepsilon_A = 1 & x_2 > h + d. \end{cases}$$

One can then easily check (see [6]) that A^1 is self-adjoint for all the values of ε_S , has a sequence of negative eigenvalues tending to $-\infty$, and that its essential spectrum is $[\beta^2, +\infty[$. Furthermore, we have the following existence result for the first positive eigenvalue:

Proposition 5.4. *There exists $\varepsilon_S^1 < 0$ such that for $\varepsilon_S < \varepsilon_S^1$, A^1 has (at least) one positive eigenvalue $\lambda_1 < \beta^2$. Furthermore, this eigenvalue satisfies: $\lambda_1 < \gamma_{\text{TM}}$.*

Proof. The characterization of positive eigenvalues given in Theorem 5.2 can be applied to the operator A^1 studied here. Consequently, λ_1 exists if and only if there exists a test function $u \in D(A^1)$ such that:

$$\beta^2 (A^1 u, u) > \|A^1 u\|_{L^2}^2.$$

Let then u^1 be a given function of x_2 satisfying (recall that h and d denote respectively the thickness of the dielectric and the thickness of the strip):

$$\begin{cases} u^1 \in \mathcal{C}^\infty([0, +\infty[), \\ u^1_{|[0,h]} = 1 \quad \text{and} \quad u^1_{|[h+d,+\infty[} = 0. \end{cases} \tag{24}$$

Since u^1 and $\frac{1}{\varepsilon} (u^1)' = \frac{1}{\varepsilon} \frac{du^1}{dx_2}$ are clearly continuous in $x_2 = h$ and $x_2 = h + d$, we have $u^1 \in D(A^1)$. Furthermore, one can easily check that:

$$\frac{(A^1 u^1, u^1)}{\|A^1 u^1\|_{L^2}^2} = \frac{(\beta^2/\varepsilon_D) h + a/\varepsilon_S}{(\beta^2/\varepsilon_D)^2 h + b/\varepsilon_S^2},$$

where we have set:

$$a = \int_h^{h+d} \left| (u^1)' \right|^2 + \beta^2 |u^1|^2 \quad \text{and} \quad b = \int_h^{h+d} \left| -(u^1)'' + \beta^2 u^1 \right|^2.$$

Thus:

$$\lim_{\varepsilon_S \rightarrow -\infty} \frac{(\beta^2/\varepsilon_D) h + a/\varepsilon_S}{(\beta^2/\varepsilon_D)^2 h + b/\varepsilon_S^2} = \varepsilon_D/\beta^2.$$

But as it has been said in Remark 3.2, we have:

$$\varepsilon_D/\beta^2 > 1/\gamma_{TM} > 1/\beta^2.$$

Thus, there exists $\varepsilon_S^1 < 0$ such that:

$$\frac{(A^1 u^1, u^1)}{\|A^1 u^1\|_{L^2(\mathbb{R}^+)}^2} > \frac{1}{\gamma_{TM}} > \frac{1}{\beta^2}, \quad \forall \varepsilon_S < \varepsilon_S^1. \tag{25}$$

This proves the existence of a positive eigenvalue λ_1 of A^1 satisfying: $\lambda_1 < \gamma_{TM} < \beta^2$. □

Remark 5.5.

(i) Obviously, some sharper estimates of λ_1 can be obtained using more accurate test functions than u^1 . This can be achieved thanks to the fact that the computations, although being heavy, are quiet explicit. In fact, our aim here was only to give an idea of the kind of methods one can use to prove existence of positive eigenvalues for the one-dimensional problem.

(ii) The fact that λ_1 satisfies $\lambda_1 < \gamma_{TM}$ will be useful in the next section, to prove existence results for the eigenvalues of the two-dimensional problem associated to A .

5.2.2. Back to the two-dimensional model

The main result of this section is given by the following theorem (recall that ℓ is the width of the strip):

Theorem 5.6. *For every $m \geq 1$, there exist $\varepsilon_S^1 < 0$ and $\ell_m > 0$ such that the number \mathcal{N} of positive eigenvalues λ of A such that $\lambda < \gamma_{\text{TM}}$ satisfies:*

$$\forall \varepsilon_S < \varepsilon_S^1, \quad \forall \ell \geq \ell_m \quad : \quad \mathcal{N} \geq m.$$

Proof. Theorem 5.2 shows that the result will be proved if there exist $\varepsilon_S^1 < 0$ and $\ell_m > 0$ such that for every $\varepsilon_S < \varepsilon_S^1$ and every $\ell \geq \ell_m$, we can find an m -dimensional subspace V_m of $D(A)$ such that:

$$\gamma_{\text{TM}}(Au, u) > \|Au\|_{L^2}^2, \quad \forall u \in V_m. \tag{26}$$

To construct such a subspace, we shall use the test function u^1 (satisfying (24)) we have used in the study of the one-dimensional problem (corresponding to $\ell = +\infty$).

Let us set:

$$u_{p,n} = \frac{1}{\sqrt{n}} \theta_p \left(\frac{x_1}{n} \right) u^1(x_2) \quad \text{and} \quad V_m^n = \text{Vect} \{u_{p,n}, p = 1, \dots, m\},$$

where: $\theta_1, \theta_2, \dots, \theta_m \in C_0^\infty(]-1, 1[)$ are supposed to be linearly independant.

Since u^1 satisfies the transmission conditions $[u^1] = \left[\frac{1}{\varepsilon} \frac{du^1}{dx_2} \right] = 0$ at the interfaces and since $\text{Supp}(u_{p,n}) \subset [-n, n]$, we have:

$$u_{p,n} \in D(A), \quad \forall \ell \geq n.$$

Thus:

$$V_m^n \subset \mathcal{V}_m(D(A)), \quad \forall \ell \geq n.$$

Let then $u_n = \sum_{p=1}^m \mu_p u_{p,n} \in V_m^n$, with $(\mu_1, \dots, \mu_m) \neq 0$. A straightforward computation shows that for $\ell \geq n$, we have:

$$\frac{(Au_n, u_n)}{\|Au_n\|_{L^2}^2} = \frac{(A^1 u^1, u^1) + \frac{\alpha'}{\alpha} \frac{1}{n^2} \left(\int_0^{+\infty} \frac{1}{\varepsilon} |u^1|^2 \right)}{\int_0^{+\infty} |A^1 u^1|^2 - 2 \frac{\alpha'}{\alpha} \frac{1}{n^2} \left(\int_0^{+\infty} \frac{1}{\varepsilon} u^1 A^1 u^1 \right) + \frac{\alpha''}{\alpha} \frac{1}{n^4} \left(\int_0^{+\infty} \frac{1}{|\varepsilon|^2} |u^1|^2 \right)},$$

where we have set:

$$\alpha = \int_{-\infty}^{+\infty} |\theta|^2, \quad \alpha' = \int_{-\infty}^{+\infty} |\theta'|^2, \quad \alpha'' = \int_{-\infty}^{+\infty} |\theta''|^2, \quad \theta = \sum_{p=1}^m \mu_p \theta_p.$$

We shall prove that for n and $|\varepsilon_S|$ large enough, we have:

$$\frac{(Au_n, u_n)}{\|Au_n\|_{L^2}^2} > \frac{1}{\gamma_{\text{TM}}}.$$

First, notice that the functionals α'/α and α''/α are bounded on the linear subspace V_θ spanned by the functions $(\theta_p)_{p=1, \dots, m}$, since α' and α'' are continuous on the compact subset of V_θ defined by $\int_{-\infty}^{+\infty} |\theta|^2 = 1$. Consequently,

we have:

$$\xi_n^1 \leq \frac{(Au_n, u_n)}{\|Au_n\|_{L^2}^2} \leq \xi_n^2, \tag{27}$$

where ξ_n^1 et ξ_n^2 are two sequences (which do not depend on ℓ) satisfying:

$$\lim_{n \rightarrow +\infty} \xi_n^1 = \lim_{n \rightarrow +\infty} \xi_n^2 = \frac{(A^1 u^1, u^1)}{\|A^1 u^1\|_{L^2}^2}.$$

It follows then from (25) and (27) that there exist $N > 0$ and $\varepsilon_S^1 < 0$ such that for $\ell \geq N$, we have:

$$u_N \in D(A) \quad \text{and} \quad \frac{(Au_N, u_N)}{\|Au_N\|_{L^2}^2} > \frac{1}{\gamma_{TM}}, \quad \forall \varepsilon_S < \varepsilon_S^1.$$

Thus inequality (26) holds, with $V_m = V_m^N$. □

6. THE ASYMPTOTIC LIMIT $\varepsilon_S \rightarrow -\infty$

Making use of the Min-Max principle, we have shown in the previous section that for $|\varepsilon_S|$ large enough and for large superconducting strips, operator A admits positive eigenvalues. In this section, we investigate the asymptotic behavior of the discrete spectrum of A as ε_S goes to $-\infty$. We will see that as expected from the physical context of the problem (*cf.* Rem. 2.5), the limit case $\varepsilon_S = -\infty$ corresponds to the case of a perfectly conducting strip. If A_E denotes the operator associated to this problem, we will show here that we can find in the neighborhood of every positive eigenvalue of A_E at least one eigenvalue of A for $|\varepsilon_S|$ large enough. The main advantage of this asymptotic result lies in the fact that contrary to A , operator A_E is elliptic and thus its spectral analysis is much more standard than the one of A .

This section is organised as follows. In Section 6.1, the case of a perfectly conducting strip is studied. In Section 6.2, we will see precisely in what sense the operator A is close to A_E for large values of $|\varepsilon_S|$. Finally, in Section 6.3, we shall use the results obtained in the previous section to prove existence of positive eigenvalues for A , once again for $|\varepsilon_S|$ large enough.

6.1. The perfectly conducting micro-strip line

Here, the Neumann boundary condition is imposed on both the strip's and the ground's plane boundaries. The associated operator A_E is thus defined as follows:

$$\left\{ \begin{array}{l} D(A_E) = \left\{ u \in H^1(\Omega_E), \operatorname{div} \left(\frac{1}{\varepsilon_E} \nabla u \right) \in L^2(\Omega_E), \partial_n u = 0 \text{ on } \Gamma \cup \Gamma_P \right\}, \\ A_E u = -\operatorname{div} \left(\frac{1}{\varepsilon_E} \nabla u \right) + \frac{\beta^2}{\varepsilon_E} u. \end{array} \right. \tag{28}$$

Since this operator is symmetric and elliptic, it is positive and self-adjoint. Furthermore, following the proof of Theorem 3.1, one can easily check that its continuous spectrum is the interval $]\gamma_{TM}, +\infty[$. Finally, using the Min-Max principle, some sufficient conditions (on the characteristics of the line) ensuring the existence of m positive eigenvalues in $]0, \gamma_{TM}[$ can be derived very easily. Indeed, using for instance the m -dimensional

subspace spanned by the m functions $(u_p)_{p=1,\dots,m}$ defined by:

$$u_p(x_1, x_2) = \begin{cases} \sin\left(\frac{p\pi}{2\ell}(2x_1 + \ell)\right) & \text{for } |x_1| < \ell/2 \text{ and } 0 < x_2 < d \\ 0 & \text{elsewhere,} \end{cases}$$

we obtain that the min-max of order m satisfies:

$$\lambda_m \leq \sup_{u \in V_m, u \neq 0} \frac{(A_E u, u)}{\|u\|_{L^2(\Omega_E)}^2} = \frac{(A_E u_m, u_m)}{\|u_m\|_{L^2(\Omega_E)}^2} = \frac{1}{\varepsilon_D} \left(\frac{m^2 \pi^2}{\ell^2} + \beta^2 \right).$$

Consequently, the Min-Max principle shows that A_E has at least m eigenvalues in $]0, \gamma_{TM}[$ as soon as the following condition is satisfied:

$$\frac{1}{\varepsilon_D} \left(\frac{m^2 \pi^2}{\ell^2} + \beta^2 \right) < \gamma_{TM}.$$

Note that for fixed values of ε_D and β , this condition is satisfied for strips that are large enough.

To conclude this section, let us give a characterization of these positive eigenvalues of A_E using the exterior Dirichlet to Neumann operator. This characterization will be very useful to compare the discrete spectra of A and A_E when $\varepsilon_S \rightarrow -\infty$.

For $\lambda \in]0, \gamma_{TM}[$ consider the operator $T_E(\lambda) : H^{1/2}(\Gamma) \rightarrow H^{-1/2}(\Gamma)$ defined for any trace $\varphi \in H^{1/2}(\Gamma)$ by:

$$T_E(\lambda)\varphi = \partial_n v_E|_\Gamma, \tag{29}$$

where $v_E \in H^1(\Omega_E)$ is the solution of the boundary value problem:

$$\begin{cases} -\operatorname{div}\left(\frac{1}{\varepsilon_E}\nabla v_E\right) + \left(\frac{\beta^2}{\varepsilon_E} - \lambda\right)v_E = 0 & (\Omega_E) \\ v_E = \varphi & (\Gamma) \\ \partial_n v_E = 0 & (\Gamma_P). \end{cases} \tag{30}$$

Before going further, let us emphasize that $T_E(\lambda)$ is well defined for every $\lambda \in [0, \gamma_{TM}[$. To check this, it suffices to prove that problem (30) is well-posed for such values of λ . Introducing the solution $w_E \in H^1(\Omega_E)$ of the well-posed boundary value problem:

$$\begin{cases} -\operatorname{div}\left(\frac{1}{\varepsilon_E}\nabla w_E\right) + \frac{\beta^2}{\varepsilon_E}w_E = 0 & (\Omega_E) \\ w_E = \varphi & (\Gamma) \\ \partial_n w_E = 0 & (\Gamma_P), \end{cases}$$

one sees that the well-posedness of (30) is equivalent to the well-posedness of the boundary value problem:

$$\begin{cases} -\operatorname{div}\left(\frac{1}{\varepsilon_E}\nabla \varphi_E\right) + \left(\frac{\beta^2}{\varepsilon_E} - \lambda\right)\varphi_E = f & (\Omega_E) \\ \varphi_E = 0 & (\Gamma) \\ \partial_n \varphi_E = 0 & (\Gamma_P), \end{cases} \tag{31}$$

where we have set: $f = -\lambda w_E \in L^2(\Omega_E)$.

Now, problem (31) has a unique solution if and only if the operator $(A_E^D - \lambda \text{Id})$ is invertible, where A_E^D is the operator defined by:

$$\begin{cases} D(A_E^D) = \left\{ u \in H^1(\Omega_E), \operatorname{div} \left(\frac{1}{\varepsilon_E} \nabla u \right) \in L^2(\Omega_E), u|_\Gamma = 0, \partial_n u|_{\Gamma_P} = 0 \right\}, \\ A_E^D u = -\operatorname{div} \left(\frac{1}{\varepsilon_E} \nabla u \right) + \frac{\beta^2}{\varepsilon_E} u. \end{cases}$$

The invertibility of A_E^D for $\lambda \in [0, \gamma_{\text{TM}}[$ follows now immediately from:

Lemma 6.1.

$$\sigma(A_E^D) = \sigma_{\text{ess}}(A_E^D) = [\gamma_{\text{TM}}, +\infty[.$$

Proof.

(i) For every $u \in D(A_E^D)$, we have:

$$(A_E^D u, u) = \int_{\Omega_E} \frac{1}{\varepsilon_E} (|\nabla u|^2 + \beta^2 |u|^2) = \int_{\Omega} \frac{1}{\varepsilon_\infty} (|\nabla \tilde{u}|^2 + \beta^2 |\tilde{u}|^2) = (A_\infty \tilde{u}, \tilde{u}),$$

where \tilde{u} is the extension of u to Ω by 0 (notice that $\tilde{u} \in H^1(\Omega)$ since $u \in H_0^1(\Omega_E)$) and A_∞ , defined by (9), is the operator corresponding to the unperturbed medium. It follows then from the study of A_∞ (see Th. 3.1) that:

$$(A_E^D u, u) = (A_\infty \tilde{u}, \tilde{u}) \geq \gamma_{\text{TM}} \|\tilde{u}\|_{L^2(\Omega)}^2 = \gamma_{\text{TM}} \|u\|_{L^2(\Omega_E)}^2,$$

and thus (since A_E^D is self-adjoint):

$$\inf \sigma(A_E^D) = \inf_{u \in D(A_E^D), u \neq 0} \frac{(A_E^D u, u)}{\|u\|_{L^2(\Omega_E)}^2} \geq \gamma_{\text{TM}},$$

showing that:

$$\sigma(A_E^D) \subset [\gamma_{\text{TM}}, +\infty[.$$

(ii) The converse inclusion can be proved by constructing for every $\lambda \geq \gamma_{\text{TM}}$ a singular sequence of A_E^D associated to λ . □

Summing up, we have shown that for $\lambda \in [0, \gamma_{\text{TM}}[$, problem (30) has a unique solution $v_E \in H^1(\Omega_E)$ for every $\varphi \in H^{1/2}(\Gamma)$, and thus that the operator $T_E(\lambda)$ such that $T_E(\lambda)\varphi = \partial_n v_E|_\Gamma$ is well defined for such values of λ .

Remark 6.2. In fact, we have proved that $T_E(\lambda)$ is well defined on $\mathbb{C} \setminus [\gamma_{\text{TM}}, +\infty[$.

Using this operator, one can see that $\lambda = \lambda_E$ is an eigenvalue of A_E if and only if:

$$\exists \varphi \in H^{1/2}(\Gamma) \quad \text{such that:} \quad T_E(\lambda_E)\varphi = 0.$$

In other words, we have the following characterization for the eigenvalues of A_E in terms of $T_E(\lambda)$:

Proposition 6.3. $\lambda_E \in]0, \gamma_{\text{TM}}[$ is eigenvalue of A_E if and only if $\xi = \lambda_E$ is a pole of the operator-valued fonction $T_E(\xi)^{-1}$ of the complex variable ξ .

6.2. Asymptotic spectral analysis of A : a boundary formulation

Let us first introduce some notations needed in the sequel. We define the positive real parameter:

$$\delta = -1/\varepsilon_S.$$

Furthermore, operator A will be noted A_δ throughout this section. Our aim here is to prove that for small values of δ , the eigenvalue problems associated to A_δ and A_E are “close”. The main difficulty in defining rigorously this property comes from the fact that the operators A_δ and A_E do not have the same domains. To overcome this difficulty, we use the boundary formulation (on Γ) of the two eigenvalue problems, obtained thanks to the Dirichlet to Neumann operators.

Let us start by writing the eigenvalue problem $A_\delta u = \lambda u$ as an equivalent problem satisfied by the new unknown: $\varphi = u|_\Gamma$. First, note that:

$$A_\delta u = \lambda u \Leftrightarrow \begin{cases} -\delta \Delta u_S + (\delta\beta^2 + \lambda) u_S = 0 & (\Omega_S) \\ -\operatorname{div} \left(\frac{1}{\varepsilon_E} \nabla u_E \right) + \left(\frac{\beta^2}{\varepsilon_E} - \lambda \right) u_E = 0 & (\Omega_E) \\ u_S - u_E = 0 & (\Gamma) \\ \delta \partial_n u_S + \frac{1}{\varepsilon_E} \partial_n u_E = 0 & (\Gamma) \\ \partial_n u_E = 0 & (\Gamma_P). \end{cases}$$

As a consequence, $\lambda \in]0, \gamma_{\text{TM}}[$ is an eigenvalue of A_δ if and only if there exists $\varphi = u_S|_\Gamma = u_E|_\Gamma \in H^{1/2}(\Gamma)$ such that:

$$T(\delta, \lambda)\varphi := (\delta T_S(\delta, \lambda) + T_E(\lambda)) \varphi = 0,$$

where $T_E(\lambda)$ is defined by (29) and (30), and $T_S(\delta, \lambda) : H^{1/2}(\Gamma) \rightarrow H^{-1/2}(\Gamma)$ is defined by:

$$T_S(\delta, \lambda)\varphi = \partial_n v_S^\delta, \tag{32}$$

where $v_S^\delta \in H^1(\Omega_S)$ is the unique solution of the Dirichlet boundary value problem:

$$\begin{cases} -\delta \Delta v_S^\delta + (\delta\beta^2 + \lambda) v_S^\delta = 0 & (\Omega_S) \\ v_S^\delta = \varphi & (\Gamma). \end{cases} \tag{33}$$

Using the boundary operators $T_S(\delta, \lambda)$ and $T_E(\lambda)$, we have the following characterization of the eigenvalues of A_δ :

Proposition 6.4. *The real number $\lambda \in]0, \gamma_{\text{TM}}[$ is an eigenvalue of A_δ if and only if $\xi = \lambda$ is a pole of the operator-valued fonction:*

$$\xi \longrightarrow T(\delta, \xi)^{-1} = (\delta T_S(\delta, \xi) + T_E(\xi))^{-1}.$$

The next step is to prove that operator $T(\delta, \lambda) = \delta T_S(\delta, \lambda) + T_E(\lambda)$ converges to $T_E(\lambda)$ (in the space of continuous operators from $H^{1/2}(\Gamma)$ onto $H^{-1/2}(\Gamma)$) as δ tends to 0, or equivalently, that $\delta T_S(\delta, \lambda)$ converges to 0 as δ tends to 0. To prove this result, we have to estimate the normal derivative of the function $v_S^\delta \in H^1(\Omega_S)$

defined by (33). The main difficulty here is that problem (33) is a singular perturbation problem when δ tends to 0. Indeed, a detailed study of this problem (which is achieved in the appendix) shows that the normal derivative of v_S^δ on Γ is not bounded as δ goes to 0 (this is due to the so called skin effect). More precisely, we have the following result:

Lemma 6.5. *Let $v_S^\delta \in H^1(\Omega_S)$ be the solution of the boundary value problem (33) for a given trace $\varphi \in H^{1/2}(\Gamma)$ and a constant $\lambda > 0$.*

Then, for every $\nu \in]0, 1/2[$, there exists a constant $C > 0$ (independent of φ and δ) such that the following estimates hold:

$$\|v_S^\delta\|_{H^1} \leq C\|\varphi\|_{H^{1/2}(\Gamma)} \delta^{-1/2} \quad , \quad \|\Delta v_S^\delta\|_{L^2} \leq C\|\varphi\|_{H^{1/2}(\Gamma)} \delta^{-1+\nu}.$$

As a consequence, we have:

$$\|\partial_n v_S^\delta\|_{H^{-1/2}(\Gamma)} \leq C\|\varphi\|_{H^{1/2}(\Gamma)} \delta^{-1+\nu}.$$

For the proof of this lemma (which is rather technical), see the appendix.

The key point now is that although the normal derivative $\partial_n v_S^\delta$ becomes infinite, $\delta \partial_n v_S^\delta$ remains bounded. This allows us to prove the following theorem, showing that the eigenvalue problems associated to A_δ and A_E are close:

Theorem 6.6. *Operator $T(\delta, \lambda) := \delta T_S(\delta, \lambda) + T_E(\lambda)$, where $T_E(\lambda)$ and $T_S(\delta, \lambda)$ are respectively defined by (29, 30) and (32, 33), satisfies:*

$$\forall \nu \in]0, 1/2[, \exists C > 0, \text{ such that: } \|T(\delta, \lambda) - T_E(\lambda)\| = \|\delta T_S(\delta, \lambda)\| \leq C\delta^\nu, \tag{34}$$

where the norm is taken in the space of bounded operators from $H^{1/2}(\Gamma)$ to $H^{-1/2}(\Gamma)$.

Proof. The result is a direct consequence of Lemma 6.5, since for every $\varphi \in H^{1/2}(\Gamma)$, we have:

$$\begin{aligned} \|(T(\delta, \lambda) - T_E(\lambda)) \varphi\|_{H^{-1/2}} &= \delta \|T_S(\delta, \lambda)\varphi\|_{H^{-1/2}} \\ &= \delta \|\partial_n v_S^\delta\|_{H^{-1/2}(\Gamma)} \\ &\leq C\|\varphi\|_{H^{1/2}(\Gamma)} \delta^\nu \end{aligned}$$

where $0 < \nu < 1/2$. □

Remark 6.7. The constant C in Theorem 6.6 depends only on ν and λ . But as it can be seen from the proof of Lemma 6.5 detailed in the appendix, C depends continuously on λ , and is thus bounded if λ is contained in a bounded region of the complex plane.

6.3. An asymptotic existence result for positive eigenvalues of A

Using the result of Theorem 6.6, we are going to prove that we can find in the vicinity of every positive eigenvalue of A_E , a positive eigenvalue of A_δ , for δ small enough. This result can be stated more precisely as follows:

Theorem 6.8. *Let $\lambda_E \in]0, \gamma_{TM}[$ be an eigenvalue of the operator A_E defined by (28), and $D_E \subset \mathbb{C}$ a disk of center λ_E . We assume that the only eigenvalue of A_E contained in D_E is λ_E .*

Then, for $\delta = -1/\varepsilon_S$ small enough, the disk D_E contains at least one eigenvalue λ of $A_\delta = A$.

Before showing this theorem, note that this eigenvalue λ is necessarily real (and positive if D_E is small enough), and consequently, Theorem 6.8 gives in particular the existence result obtained in Theorem 5.6.

Proof. We are going to use here the characterization of the eigenvalue problems associated to A_E and A_δ , respectively given by Propositions 6.3 and 6.4.

So assume that $T_E(\xi)^{-1}$ has a pole at $\xi = \lambda_E$, and let us prove that there exists $\delta_0 > 0$ such that for $0 < \delta < \delta_0$, $(T(\delta, \xi))^{-1} = (\delta T_S(\delta, \xi) + T_E(\xi))^{-1}$ has at least one pole in the disk D_E .

If not, there would exist a sequence δ_n tending to 0, such that the family of operators $(T(\delta_n, \xi)^{-1})_{n \in \mathbb{N}}$ is holomorphic on D_E . Thus, if \mathcal{C} is a closed curve included in D_E and containing λ_E , then:

$$\int_{\mathcal{C}} T(\delta_n, \xi)^{-1} d\xi = 0, \quad \forall n \in \mathbb{N}. \tag{35}$$

The idea now is to take the limit $n \rightarrow +\infty$ in this relation.

The key point of the proof is that operator $T(\delta_n, \xi)^{-1}$ converges to $T_E(\xi)^{-1}$ as n tends to $+\infty$ uniformly on \mathcal{C} . To prove this assertion, one should first notice that:

$$T(\delta_n, \xi)^{-1} - T_E(\xi)^{-1} = T(\delta_n, \xi)^{-1} (T_E(\xi) - T(\delta_n, \xi)) T_E(\xi)^{-1}. \tag{36}$$

Now, taking for instance $\nu = 1/4$ in Theorem 6.6, one obtains the existence of a positive constant C (independent of ξ , see Rem. 6.7) such that:

$$\|T_E(\xi) - T(\delta_n, \xi)\| \leq C\delta_n^{1/4}, \quad \forall \xi \in \mathcal{C}. \tag{37}$$

On the other hand, we have:

$$\|T_E(\xi)^{-1}\| \leq C, \quad \forall \xi \in \mathcal{C}.$$

Thus, to conclude, it remains to check that the family $(T(\delta_n, \xi)^{-1})_{n \in \mathbb{N}}$ is uniformly bounded on \mathcal{C} . But:

$$T(\delta_n, \xi)^{-1} = (T_E(\xi) + \delta_n T_S(\delta_n, \xi))^{-1} = T_E(\xi)^{-1} (\text{Id} + \delta_n T_S(\delta_n, \xi) T_E(\xi)^{-1})^{-1},$$

and by Theorem 6.6, there exists $C > 0$ such that:

$$\|\delta_n T_S(\delta_n, \xi) T_E(\xi)^{-1}\| \leq C\delta_n^{1/4}.$$

Thus, using the Neumann series of $\text{Id} + \delta_n T_S(\delta_n, \xi) T_E(\xi)^{-1}$ one obtains the existence of $N > 0$ (independent of ξ) such that for $n \geq N$ the following estimate holds:

$$\|(\text{Id} + \delta_n T_S(\delta_n, \xi) T_E(\xi)^{-1})^{-1}\| \leq \frac{1}{1 - \|\delta_n T_S(\delta_n, \xi) T_E(\xi)^{-1}\|} \leq \frac{1}{1 - C\delta_n^{1/4}}, \quad \forall \xi \in \mathcal{C}.$$

Thus, for $n \geq N$, we have:

$$\|T(\delta_n, \xi)^{-1}\| \leq C, \quad \forall \xi \in \mathcal{C}. \tag{38}$$

Using (37) and (38) in (36), we get:

$$\|T(\delta_n, \xi)^{-1} - T_E(\xi)^{-1}\| \leq C\delta_n^{1/4}, \quad \forall \xi \in \mathcal{C}.$$

One can thus take the limit in (35) and obtain:

$$\int_{\mathcal{C}} T_E(\xi)^{-1} d\xi = 0. \tag{39}$$

The contradiction comes now from the fact that since operator $T_E(\xi)^{-1}$ has a pole at $\xi = \lambda_E$, we have:

$$\int_C T_E(\xi)^{-1} d\xi = 2i\pi \operatorname{Res}(T_E(\xi)^{-1}, \xi = \lambda_E) \neq 0,$$

where $\operatorname{Res}(T_E(\xi)^{-1}, \xi = \lambda_E)$ denotes the residue of $T_E(\xi)^{-1}$ at $\xi = \lambda_E$.

Thus, $T(\delta, \xi)^{-1}$ has necessarily a pole in D_E for δ small enough, and Theorem 6.8 is proved. □

Remark 6.9. In fact, the proof of Theorem 6.8 also shows that if the disk D_E does not contain any eigenvalue of A_E , then it contains no eigenvalues of A_δ . Indeed, if $T_E(\xi)^{-1}$ is bounded for some ξ by a constant C_E , then for δ small enough, we have:

$$\|T(\delta, \xi)^{-1}\| = \left\| T_E(\xi)^{-1} (\operatorname{Id} + \delta T_S(\delta, \xi) T_E(\xi)^{-1})^{-1} \right\| \leq \frac{C_E}{1 - C\delta^{1/4}} \leq C_E,$$

and $T(\delta, \xi)^{-1}$ is thus bounded.

APPENDIX

This appendix is devoted to the proof of Lemma 6.5, which gives an estimate of the normal derivative $\partial_n v_S^\delta|_\Gamma$ of the solution v_S^δ of the boundary value problem:

$$\begin{cases} -\delta \Delta v_S^\delta + (\delta\beta^2 + \lambda) v_S^\delta = 0 & (\Omega_S) \\ v_S^\delta = \varphi & (\Gamma). \end{cases}$$

More precisely, we have to prove that for every $\nu \in]0, 1/2[$, there exists a constant $C > 0$ (independent of φ and δ) such that:

$$\begin{aligned} \|v_S^\delta\|_{H^1} &\leq C\|\varphi\|_{H^{1/2}(\Gamma)} \delta^{-1/2} \quad , \quad \|\Delta v_S^\delta\|_{L^2} \leq C\|\varphi\|_{H^{1/2}(\Gamma)} \delta^{-1+\nu}, \\ \|\partial_n v_S^\delta\|_{H^{-1/2}(\Gamma)} &\leq C\|\varphi\|_{H^{1/2}(\Gamma)} \delta^{-1+\nu}. \end{aligned}$$

Throughout this appendix, we will denote by $\|\cdot\|_{L^2}$ and $\|\cdot\|_{H^1}$ the usual norms in $L^2(\Omega_S)$ and $H^1(\Omega_S)$, and by (\cdot, \cdot) the canonical scalar product of $L^2(\Omega_S)$. Furthermore, for the sake of simplicity, C will always denote a constant which is independent of φ and δ .

First, note that the last estimate follows immediately from the two first ones, since by Green's formula, we have:

$$\|\partial_n v_S^\delta\|_{H^{-1/2}(\Gamma)} \leq C (\|\Delta v_S^\delta\|_{L^2} + \|v_S^\delta\|_{H^1}).$$

To obtain the two first estimates, we introduce the solution $w_S \in H^1(\Omega_S)$ of the following elliptic boundary value problem:

$$\begin{cases} -\Delta w_S + \beta^2 w_S = 0 & (\Omega_S) \\ w_S = \varphi & (\Gamma). \end{cases}$$

Note that w_S satisfies

$$\|w_S\|_{H^1} + \|\Delta w_S\|_{L^2} \leq C\|\varphi\|_{H^{1/2}(\Gamma)}. \tag{40}$$

Then v_S^δ solves problem (33) if and only if $w_S^\delta = v_S^\delta - w_S$ satisfies:

$$\begin{cases} -\delta \Delta w_S^\delta + (\delta\beta^2 + \lambda) w_S^\delta = f & (\Omega_S) \\ w_S^\delta = 0 & (\Gamma), \end{cases} \tag{41}$$

where:

$$f = -\delta \Delta w_S + (\delta\beta^2 + \lambda) w_S = \lambda w_S \in H^1(\Omega),$$

and thus:

$$\|f\|_{L^2} \leq C\|\varphi\|_{H^{1/2}(\Gamma)}. \tag{42}$$

It follows then from (40) that Lemma 6.5 will be proved if we can show that:

- (i) $\|w_S^\delta\|_{H^1} \leq C\|\varphi\|_{H^{1/2}(\Gamma)} \delta^{-1/2}.$
- (ii) $\|\Delta w_S^\delta\|_{L^2} \leq C\|\varphi\|_{H^{1/2}(\Gamma)} \delta^{-1+\nu}.$

To prove (i), we use the variational formulation of problem (41), which reads:

$$a^\delta(w_S^\delta, w) = (f, w), \quad \forall w \in H_0^1(\Omega_S). \tag{43}$$

where:

$$a^\delta(u, v) = \delta \int_{\Omega_S} (\nabla u \cdot \nabla v + \beta^2 uv) + \lambda \int_{\Omega_S} uv.$$

Choosing $w = w_S^\delta$ in (43), one gets:

$$\begin{cases} \delta \|\nabla w_S^\delta\|_{L^2}^2 \leq \|f\|_{L^2} \|w_S^\delta\|_{L^2}, \\ \lambda \|w_S^\delta\|_{L^2} \leq \|f\|_{L^2}. \end{cases}$$

Plugging the second inequality into the first one shows that:

$$\begin{cases} \delta \|\nabla w_S^\delta\|_{L^2}^2 \leq \lambda^{-1} \|f\|_{L^2}^2, \\ \lambda \|w_S^\delta\|_{L^2} \leq \|f\|_{L^2}. \end{cases}$$

Using (42), we obtain that:

$$\begin{cases} \delta^{1/2} \|\nabla w_S^\delta\|_{L^2} \leq C\|\varphi\|_{H^{1/2}} \\ \|w_S^\delta\|_{L^2} \leq C\|\varphi\|_{H^{1/2}} \end{cases} \tag{44}$$

and the estimate (i) is thus proved .

To prove (ii), we proceed as follows.

Step 1: We first notice that from (41):

$$\Delta w_S^\delta = \delta^{-1} (\lambda w_S^\delta - f) + \beta^2 w_S^\delta. \tag{45}$$

Since $\|w_S^\delta\|_{L^2} \leq C\|\varphi\|_{H^{1/2}}$, we only have to obtain an estimate on:

$$e^\delta = \lambda w_S^\delta - f.$$

Step 2: Let us show that e^δ satisfies:

$$\delta^{-\nu} e^\delta \rightharpoonup 0 \text{ weakly in } L^2(\Omega_S), \text{ for } 0 < \nu < 1/2. \tag{46}$$

The variational formulation (43) shows that:

$$(\lambda w_S - f, w) = -\delta^{1/2} \left(\delta^{1/2} \nabla w_S^\delta, \nabla w \right) - \delta \beta^2 (w_S^\delta, w), \quad \forall w \in H_0^1(\Omega_S),$$

or equivalently:

$$(\delta^{-\nu} e^\delta, w) = -\delta^{1/2-\nu} \left(\delta^{1/2} \nabla w_S^\delta, \nabla w \right) - \delta^{1-\nu} \beta^2 (w_S^\delta, w), \quad \forall w \in H_0^1(\Omega_S).$$

Property (46) is then a direct consequence of the estimates (44).

Step 3: The previous step shows in particular that $\delta^{-\nu} e^\delta$ is bounded in $L^2(\Omega_S)$. Thus, the family E^δ of linear continuous operators defined by:

$$E^\delta : \varphi \in H^{1/2}(\Gamma) \longrightarrow E^\delta(\varphi) = \delta^{-\nu} e^\delta = \delta^{-\nu} (\lambda w_S^\delta - f) \in L^2(\Omega_S)$$

satisfies:

$$\forall \varphi \in H^{1/2}(\Gamma), \exists C(\varphi) > 0 \text{ such that: } \|E^\delta(\varphi)\|_{L^2} \leq C(\varphi), \quad \forall \delta \leq 1.$$

The Banach-Steinhaus theorem shows then that in fact the family is uniformly bounded (with respect to φ). In other words:

$$\exists C > 0 \text{ such that: } \|E^\delta(\varphi)\|_{L^2} \leq C\|\varphi\|_{H^{1/2}}, \quad \forall \delta \leq 1, \forall \varphi \in H^{1/2}(\Gamma).$$

We have thus proved that for $0 < \nu < 1/2$:

$$\exists C > 0 \text{ such that: } \|\lambda w_S^\delta - f\|_{L^2} \leq C\|\varphi\|_{H^{1/2}} \delta^\nu, \quad \forall \delta \leq 1, \forall \varphi \in H^{1/2}(\Gamma).$$

Summing up these results and using (45) and (44), we have proved that for every $0 < \nu < 1/2$:

$$\|\Delta w_S^\delta\|_{L^2} \leq C\|\varphi\|_{H^{1/2}(\Gamma)} \delta^{-1+\nu},$$

which is nothing but (ii).

REFERENCES

[1] A. Bamberger and A.-S. Bonnet, Mathematical Analysis of the Guided Modes of an Optical Fiber. *SIAM J. Math. Anal.* **21** (1990) 1487–1510.
 [2] A.-S. Bonnet-Bendhia, G. Caloz and F. Mahé, Guided Modes of Integrated Optical Guides. A Mathematical Study. *IMA J. Appl. Math.* **60** (1998) 225–261.
 [3] A.-S. Bonnet-Bendhia, M. Dauge and K. Ramdani, Analyse Spectrale et Singularités d’un Problème de Transmission non Coercif. *C. R. Acad. Sci. Paris Sér. I* **328** (1999) 717–720.
 [4] A.-S. Bonnet-Bendhia, J. Duterte and P. Joly, Mathematical Analysis of Elastic Surface Waves in Topographic Waveguides. *Math. Models Methods Appl. Sci.* **9** (1999) 755–798.

- [5] A.-S. Bonnet-Bendhia and K. Ramdani, Mathematical Analysis of Conducting and Superconducting Transmission Lines. *SIAM J. Appl. Math.* **60** (2000) 2087–2113.
- [6] J.-M. Cognet, *Étude des modes guidés dans une ligne supraconductrice : le cas monodimensionnel*. Rapport Interne n°295, ENSTA, Paris (1997).
- [7] R.E. Collins, *Foundations for microwave engineering*. Mc Graw-Hill Inc. (1992).
- [8] P. Joly and C. Poirier, Mathematical Analysis of Electromagnetic Open Wave-guides. *RAIRO Modél. Math. Anal. Numér.* **29** (1995) 505–575.
- [9] J.G. Ma and I. Wolff, Modeling the Microwave Properties of Superconductors. *IEEE Trans. Microwave Theory Tech.* **43** (1995) 1053–1059.
- [10] D. Marcuse, *Theory of Dielectric Optical Waveguide*. Academic Press, New-York (1974).
- [11] K.K Mei and G. Liang, Electromagnetics of Superconductors. *IEEE Trans. Microwave Theory Tech.* **44** (1991) 1545–1552.
- [12] A.D. Olver, *Microwave and Optical Transmission*. J. Wiley & Sons Ed. (1992).
- [13] K. Ramdani, *Lignes Supraconductrices : Analyse Mathématique et Numérique*. Ph.D. thesis, University of Paris VI, France (1999).
- [14] M. Reed and B. Simon, *Methods of Modern Physics, Analysis of Operators*. Academic Press (1980).